

Structural behavior of an innovative all-precast concrete dual system for residential buildings

Adrian M. Ioani and Eusebiu Tripa

- A new all-precast concrete system was used in Romania to construct a residential building.
- To validate the quality and performance of this type of structure, an extensive program of theoretical analyses and structural tests (including shake table tests) was conducted.
- Due to its functional and technical advantages, high productivity, and low cost, the building system has been used in more than 500 flats in Transylvania, Romania.

The performance of a structure is mainly linked to its strength, stiffness, and ductility, although functionality, aesthetics, speed of construction, and economy are also significant.

The following functional requirements should be taken into consideration:

- Long spans with floor space uninterrupted by columns or structural walls give users maximum flexibility.
- A maximum floor-to-floor height allows adequate spaces and a reduced overall building height.
- Open-space apartments or offices (adaptable floors) can accommodate future tenant alterations with maximum speed and minimum disruption or cost.

It is well known that the economic performance of a structural system greatly depends on the quantities of materials per square meter (for example, concrete, reinforcing bars, and strands), but the real construction cost can also depend on speed of construction, local market conditions, availability of labor and specialized equipment, and other factors.

Flat-slab structures in seismic zones

Performance characteristics related to building functionality, aesthetics, and economy can be encountered in the case of structures made of slabs and columns, the so-called typical flat-slab structures. These structures carry vertical and lateral forces and achieve their lateral stability by frame action generated by the interaction of columns and slabs.

In many cases, such as multistory buildings or structures in seismic areas, pure flat-slab structures have to be altered by the addition of vertical elements, such as shear walls or steel bracing systems, leading to dual systems. The equivalent frames, comprising slabs and columns, mainly ensure the transfer of gravity loads and a portion of the seismic loads, while the structural wall system provides the lateral resistance and stiffness of the building¹ so that such a dual structure can be successfully used even in areas with high seismic activity.

To improve the competitiveness of such a structure type and considering constructability as a powerful tool for reducing the cost and the time of construction, the designers' interest has focused on a standard precast concrete structure using fewer elements with standard dimensions that can be produced in large numbers on an industrial basis.

Objectives

In an attempt to solve the difficult problem of the construction of residential buildings in Romania, taking into consideration the previously mentioned factors and requirements, a design team from the Design Institute of Hunedoara in Romania, led by Eusebiu Tripa, proposed a new all-precast concrete system of a dual flat-slab structure type.

A complex program, including theoretical studies and many experimental tests,² preceded the national-scale promotion of this system. Academics from Romanian civil engineering faculties in Jassy, Cluj, Timișoara, and Bucharest; researchers from INCERC-Bucharest (National Building Research Institute) and from the INCERC departments of Timișoara, Jassy, and Cluj; architects; and civil engineers participated in this program.

This paper presents the main characteristics of the new building system, the principal features of the experimental program that preceded its launch on the market, and the conclusions concerning the structural performance of the system.

Precast concrete dual flat-slab structure

Structure characteristics

The structural system presented in this paper is dedicated to residential buildings with up to nine stories, and it

mainly consists of long precast concrete columns—a unit is from 5.40 m (18 ft) to 11.40 m (37.4 ft) long—and precast concrete flat-slab panels with spans of 3.60 m (12 ft) to 6.00 m (20 ft).

The promotion of such a system in seismic areas was conditioned by the use of a limited number of structural walls in the structure, leading to a dual structural system of the frame-wall type (**Fig. 1**). **Figure 2** shows this innovative precast concrete structure during erection in the city of Deva, Romania.

In Europe, Romania is considered to have a high level of seismic risk, where earthquakes over 7 on the Richter scale occur quite frequently. Bucharest is the most vulnerable capital in Europe.³ The seismic response to the accelerograms recorded in Bucharest during the 1977 Vrancea earthquake (magnitude of earthquake on the moment magnitude scale M_w equal to 7.5 with 0.2g peak ground acceleration, where g is acceleration due to gravity) shows uncommonly high displacement demands. Extensive non-structural damage during this earthquake was reported due to large lateral displacements. For this reason, the Romanian *Seismic Design Code* P 100-92⁴ limits the allowable interstory drift to 0.35% for buildings with infill walls interacting with the frame structure when the structure is checked in the serviceability limit state (SLS). The new Romanian *Seismic Design Code* P 100-1/2006⁵ introduced a more relaxed value of 0.5% for allowable interstory drift for verifications in the SLS, comparable to that specified by FEMA 356/2000⁶ for shear wall structures when immediate occupancy structural performance level is considered.

Precast concrete columns

Columns are precast concrete elements with variable lengths, a function of the structure height. Columns may extend over one or more levels depending on technological, strength, and cost criteria. Typically, the joints between columns and slabs are not filled with concrete, and the longitudinal reinforcement in the columns is continuous (**Fig. 3**). The reinforcement resists the loads generated during the transport, handling, and assembling operations when the concrete is missing in the joint zone of the column.

The analytical and experimental studies performed by the authors² on up to 14.00-m-long (46 ft) precast concrete columns have shown that the most efficient solution lies in the precasting of 9.00-m-long (30 ft) columns, which correspond to three-story buildings.

In taller buildings, more members are assembled to form a column. The connection between the precast concrete members is of a bayonet type: the reinforcing bars from the upper member are inserted into the sheaths at the end of the lower column (**Fig. 3**).

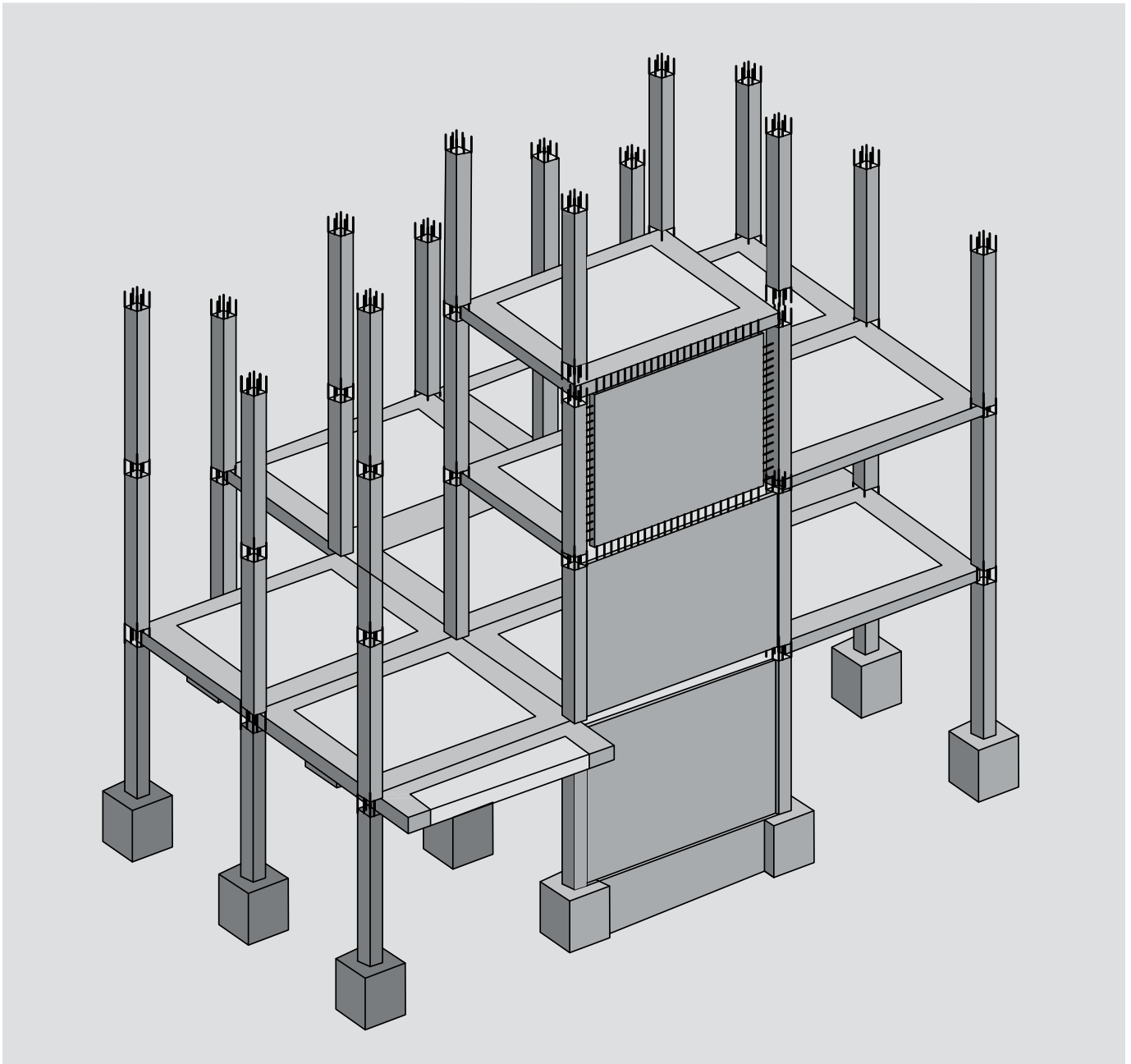

Figure 1. Types of elements in the precast concrete dual flat-slab structure.



Figure 2. All-precast concrete dual structure during erection.

Precast concrete floors

The floors are made of large precast concrete flat-slab panels supported at the corners by mechanical devices fixed on the columns.

The spacing between the columns, usually ranging from 3.00 m (10 ft) to 6.00 m (20 ft), dictates the span of precast concrete slab panels; the floor panel is of the ribbed flat-slab type (**Fig. 4**). The continuity of the precast concrete floor is achieved by narrow cast-in-place concrete strips reinforced by longitudinal bars and horizontal loops (**Fig. 4**).

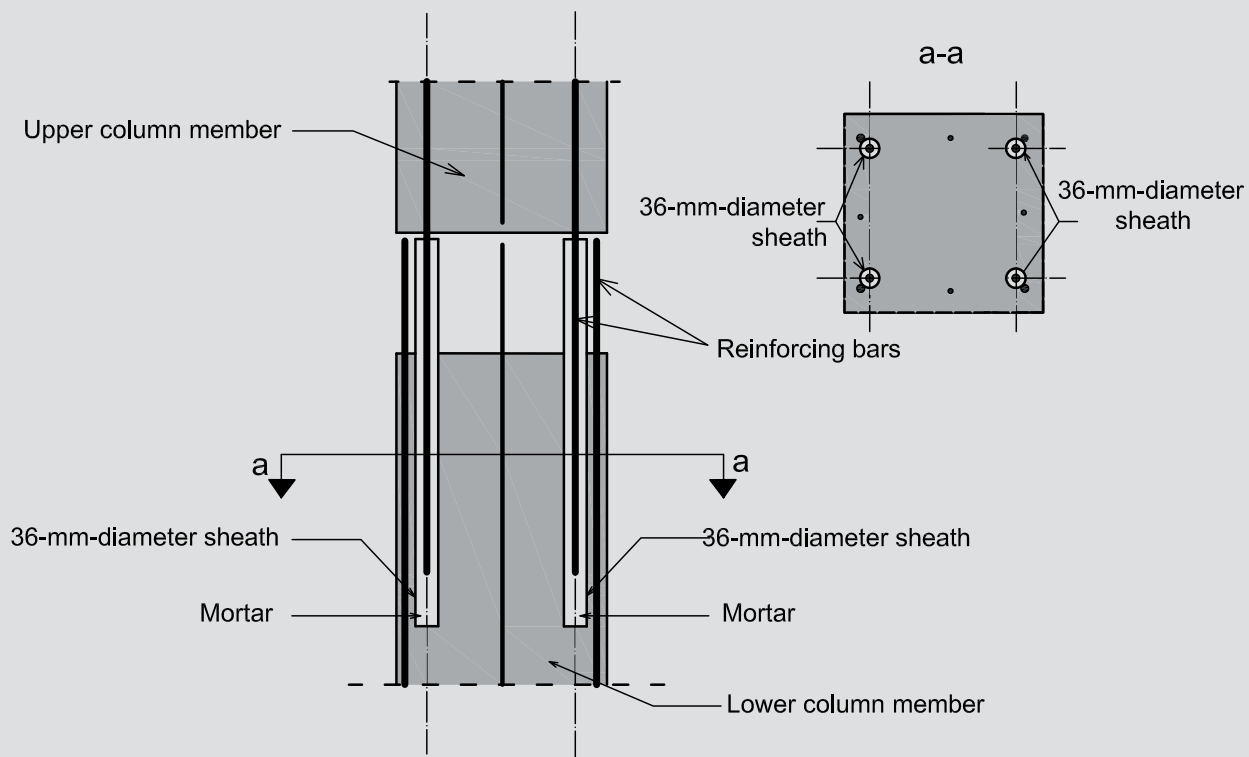

Figure 3. Connection between column members. Note: 1 mm = 0.0394 in.

Precast concrete shear walls

The shear wall comprises large reinforced precast concrete

panels spanning between adjacent columns. Through their horizontal connections, the panels provide the structural wall continuity along its height. Through their vertical

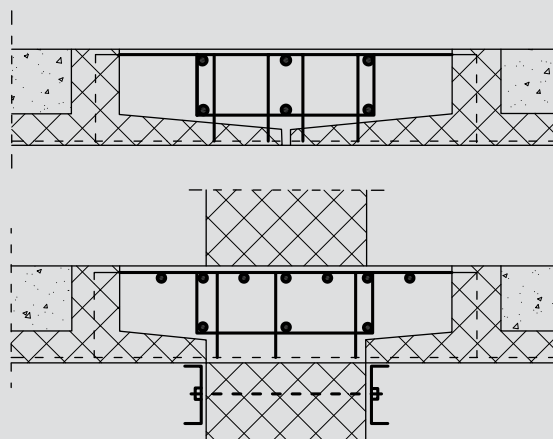
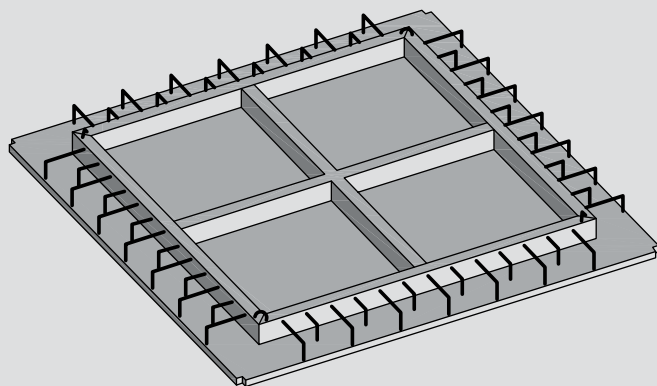

Figure 4. Precast concrete flat-slab panel and connections between the panels.

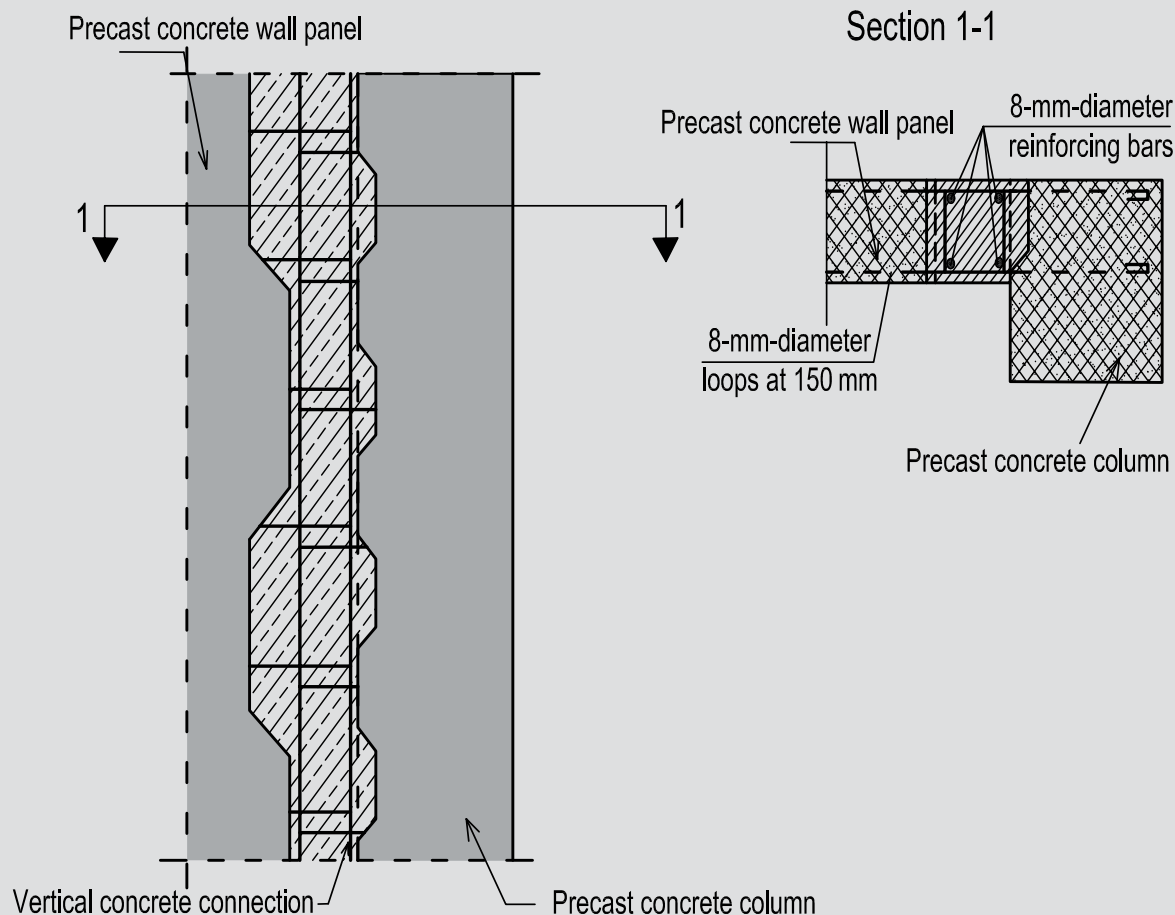

Figure 5. Vertical column–wall panel connection.

connections (column-panel joints) they make up a dual structural system, combining frames with structural walls (Fig. 2 and Fig. 5).

Experimental program

Objectives of the program

The structural behavior of a system that incorporates precast concrete members may differ substantially from that of a comparable monolithic cast-in-place system. The precast concrete members should be assembled and connected to produce a structural system capable of resisting vertical and lateral forces due to shrinkage, creep, temperature changes, elastic deformation, wind, or earthquake.

The design and detailing of the connections to transmit such forces are especially important to performance. Connections are essential to the integrity of the structural system.

Taking into consideration the novelty of the proposed system and the overall behavior of the precast concrete structure, “the adequacy of connections to transfer forces

between precast concrete members should be determined by analyses or by tests.”⁷

In addition, section 21.2.1.5 says that a precast concrete structural system “may be used for earthquake resistance if it is demonstrated by experimental evidence and analysis that the proposed system will have strength and toughness equal to or exceeding those provided by a comparable monolithic reinforced concrete structure.”⁷

To assess the structural quality and the performance of this structural system designed for seismic zones, the research team conducted an extensive analytical and experimental study. The research program² included tests on column-to-column joints, experimental tests on a precast concrete structural wall subassembly, postelastic computer analysis of precast concrete structural walls, tests on a full-scale assemblage of columns and precast concrete flat slabs subjected to gravity forces, shake table tests on a structure prototype (scale 1:4), and in-place dynamic tests on a real five-story building. In this large scientific program, researchers from three universities and four institutes and structural designers from two design institutes were involved.

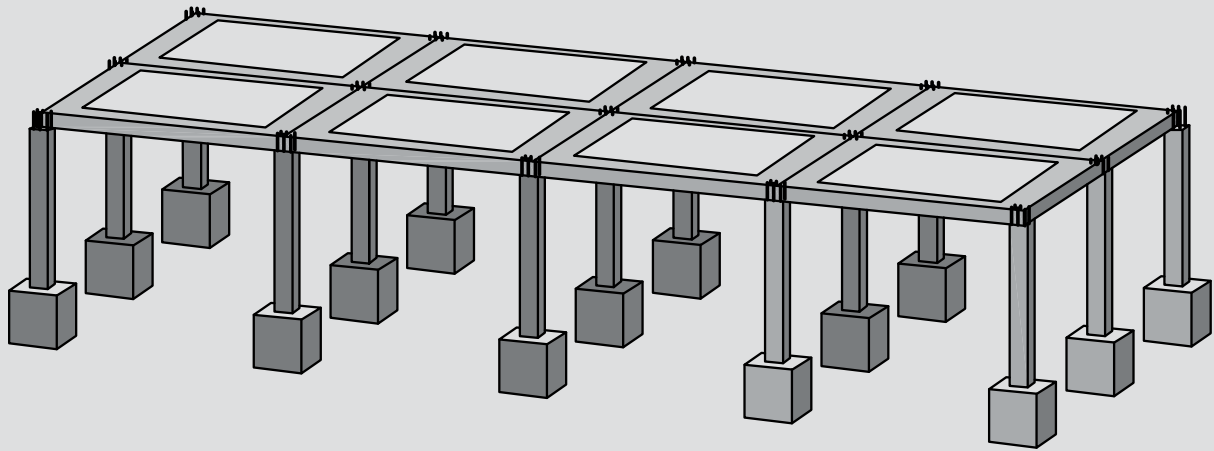

Figure 6. Full-scale precast concrete structure under gravity loads.

Flat-slab structure under gravity loads

The full-scale test of an assemblage of precast concrete columns and slabs was performed to observe the behavior of the precast concrete flat-slab panels, the connections between panels, and the column-to-slab connections under gravity loads. The behavior up to the failure of the entire floor system and the problem of slab punching were also studied.

The assemblage comprised eight square precast concrete slab panels of 3.60 m (12 ft) each and 15 square columns of 350 mm (14 in.) (**Fig. 6**).

The authors used the equivalent frame method accepted by many design codes, including the American Concrete Institute (ACI 318-08),⁷ European (EN 1992-1-1:2004),⁸ and Romanian standards (SR EN 1992-1-1:2004⁹ and STAS 10107/1-90).¹⁰ The designers calculated theoretical values for cracking load P_{cr}^d of 5.50 kN/m² (115 lb/ft²) and ultimate gravity load P_u^d of 7.70 kN/m² (160 lb/ft²).

The strains in the concrete and reinforcing bars, the vertical displacement of the precast concrete panels, and the displacements of the connections between the slab panels were recorded. **Figure 7** shows a typical applied load-displacement diagram recorded during the test (**Fig. 6**) at the midspan of the panel.

The first cracks developed at 4.40 kN/m² (92 lb/ft²) in the longitudinal edge connections and at 9.90 kN/m² (210 lb/ft²) in the middle of the panel. The experimental ultimate gravity load P_u^{exp} of 15.90 kN/m² (332 lb/ft²) was reached in the last loading stage and corresponded to the initiation of slab punching in the vicinity of columns. The ratio of 2.10 between the experimental and the theoretical (design) values of the ultimate load (P_u^{exp}/P_u^d) confirms the gener-

ally good behavior of the structure under vertical loads and underlines the large load-bearing capacity of the structure.

The shape of the gravity load-vertical deflection $P-\Delta^v$ diagrams reveals an elastic behavior of the structure with 26.80% to 39.70% permanent irreversible deformations and 60.30% to 73.20% elastic recovery (**Fig. 7**).

The maximum vertical displacement Δ_{max}^v of 7.3 mm (0.29 in.) does not exceed the allowable vertical displacement Δ_a^v of $L/350$ equal to 9.3 mm (0.36 in.) given by the Romanian design code for concrete structures STAS 10107/0-90.¹¹ The monolithic connections between the slab precast concrete panels, which have 8 mm loops at 150 mm (0.3 in. loops at 6 in.) spacing and longitudinal reinforcing bars, ensure complete integrity of the precast concrete floor, including its flexural and shear integrity.

Dual precast concrete structural walls' subassemblage under lateral loading

The experimental program focused on the general behavior of the precast concrete structural walls under static alternate-reversed loadings in all ranges—elastic, cracking, postelastic, and failure—as well as the behavior of the vertical connections, horizontal connections, and joints between precast concrete column members.

The tested subassemblage was designed to model at scale 1:2.5 the structural behavior of a real precast concrete structural wall with eight stories. The unit's components are monolithic concrete foundations under each shear wall, precast concrete columns of two or three stories for each member, precast concrete shear wall panels on the height of a floor, and precast concrete slab panels (**Fig. 8**).

The loading of the model was accomplished by gravity

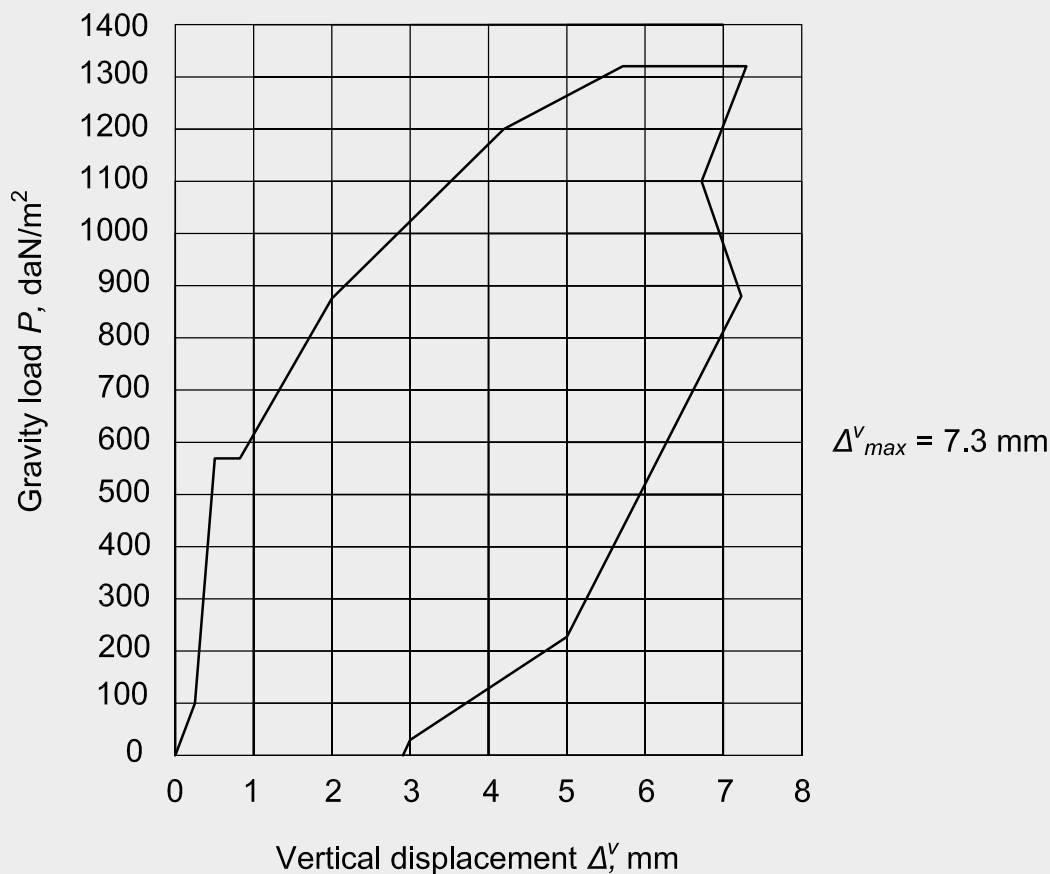

$\Delta^v_{max} = 7.3 \text{ mm}$

Figure 7. Gravity load–vertical displacement P – Δ^v recorded at the middle of the panel. Note: Δ^v_{max} = experimental maximum vertical deflection. 1 mm = 0.0394 in.; 1 daN/m² = 0.208 lb/ft².

loads N_g (dead load) so that the same compressive stress as in a real eight-story shear wall could be reached at each level.

The vertically applied forces N_1 (Fig. 8) compensate in the model for the effect of the reduction of the upper three floors of the real structural wall. These adjustments from the real structure to the model did not alter the results of the experiment. On the lower third of the shear wall, the part of maximum interest, the bending moments are practically equal and the shear forces are generally slightly higher than in the real structure.

Previous tests (Maniu et al.)¹² had shown that the cracking does not extend beyond the lower third of the structural wall. The horizontal load H was applied in alternate cycles following the principle of imposed displacements, where Δ is the top lateral displacement of the experimental model and Δ_y is the top lateral displacement at the first yield of the steel reinforcement (Fig. 9).

The large subassembly, measuring 2.02 m × 1.62 m × 5.95 m (6.62 ft × 5.31 ft × 19.50 ft), was loaded vertically and horizontally (Fig. 8). The principal observations and conclusions include the following:

- The cracking extended only along the height of three stories. Although it was all-precast concrete, the structural wall subassembly (column–shear wall panels–column) behaved at cracking as a monolithic structural wall, the cracks of the columns being continuous through connections and through precast concrete panels. The cracks are typical of bending.
- The main cracks that finally led to failure developed only after the imposed $3\Delta_y$ cycle (Fig. 9). In the monolithic area (vertical connections), the cracks were narrow, having a width under 0.20 mm (0.0078 in.) throughout the test (Fig. 10).
- The column-to-column joint behaved well. The cracks were insignificant in two of the joints and totally absent in the other two joints.

- Failure of the subassembly occurred because of the concrete spalling and crushing in compression and because of the failure of a few column reinforcing bars that, after 26 cycles, buckled locally between the hoops (Fig. 10). The predicted ultimate capacity was 2% smaller than the experimental one, 360 kN-m compared with 354 kN-m (266 kip-ft compared with 261 kip-ft).
- The measured lateral load–top displacement hysteretic loops (Fig. 11), by their convex aspect, showed a behavior typical of long shear walls mainly subjected to the bending moment. There was no pinching in the last cycles, demonstrating the integrity of the connection and, practically, the absence of slipping between the precast concrete elements (column to panel).
- The maximum values of the joint slipping attained in the cycle $4\Delta_y$ did not exceed 0.30 mm (0.012 in.) in the vertical column-to-panel joint and was only 0.10 mm (0.0039 in.) in the horizontal panel-to-panel joint.
- The area enclosed by the hysteretic loops indicated large energy absorption. The loops were stable. The stiffness reduction, after three or four cycles under the same imposed displacement, did not exceed 10% (Fig. 11).
- The experimental displacement corresponding to the design code force of 52.8 kN (11.9 kip) was in good agreement (5% higher) with the theoretical one. The experimental ultimate top lateral displacement recorded in the last failure cycle Δ_{max}^{exp} of 112.3 mm (4.421 in.) was 26% smaller than the design ultimate top lateral displacement Δ_{max}^d of 153.0 mm (6.02 in.). This ratio indicates that in reality, the lateral rigidity of the precast concrete model, after 27 cycles of alternate loads, is greater than the stiffness assumed in design.
- The lateral stiffness of the experimental specimen was remarkable. After 23 cycles of loading, the lateral interstory drift measured at the uppermost level in the $4\Delta_y$ cycle was only 1/205.
- The ultimate displacement ductility factor Δ_u/Δ_y (where Δ_u is ultimate top lateral displacement) attained during the test was 5.25. The structural subassembly behaved well from this point of view, too.

Shake table tests on a five-story prototype

The most comprehensive experimental program was the testing of a 1:4 scale model of a five-story building on a 140 kN (315 kip) shake table (Fig. 12). The model structure was tested in the transverse direction.

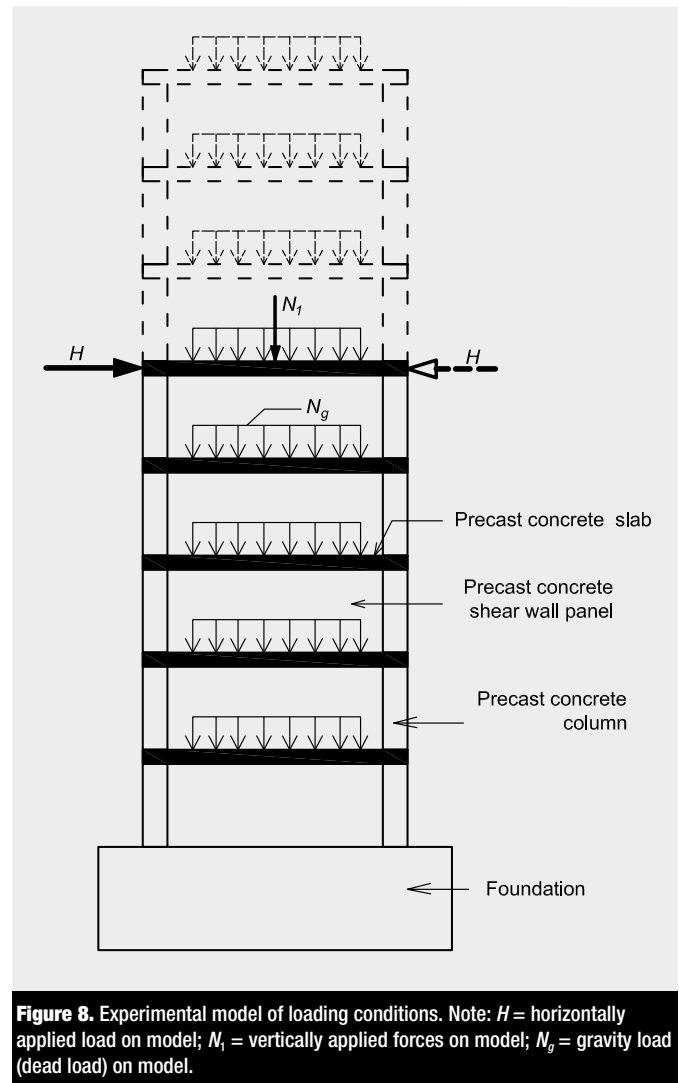

Figure 8. Experimental model of loading conditions. Note: H = horizontally applied load on model; N_1 = vertically applied forces on model; N_g = gravity load (dead load) on model.

The dual precast concrete structure consisted of eight shear walls and 24 frame columns, interconnected by five precast concrete flat slabs (Fig. 12).

The dynamic response of this precast concrete dual system was established during four static tests, five tests to determine the dynamic characteristics of the structure, and 17 dynamic tests.

The dynamic tests took 900 seconds in all and had about 70 acceleration peaks a_{0max} of more than 1 m/sec² (3 ft/sec²) from those 1200 peak accelerations applied. The real precast concrete structure and the experimental prototype were designed for a seismic intensity of VIII on the modified Mercalli intensity scale (MM scale).

The experimental program included dynamic tests with an artificial Housner-Jennings type earthquake (a_{0max} of 1.108 ÷ 2.632 m/sec² [3.635 ÷ 8.635 ft/sec²]); 1977 Vrancea, Romania, earthquake (a_{0max} of 2.775 ÷ 3.885 m/sec² [9.104 ÷ 12.75 ft/sec²]); 1940 El Centro, Calif., earthquake (a_{0max} of 2.775 m/sec² [9.104 ft/sec²]); artificial Jassy, Romania, earthquake (a_{0max} of 4.163 ÷ 6.383 m/sec² [13.66 ÷

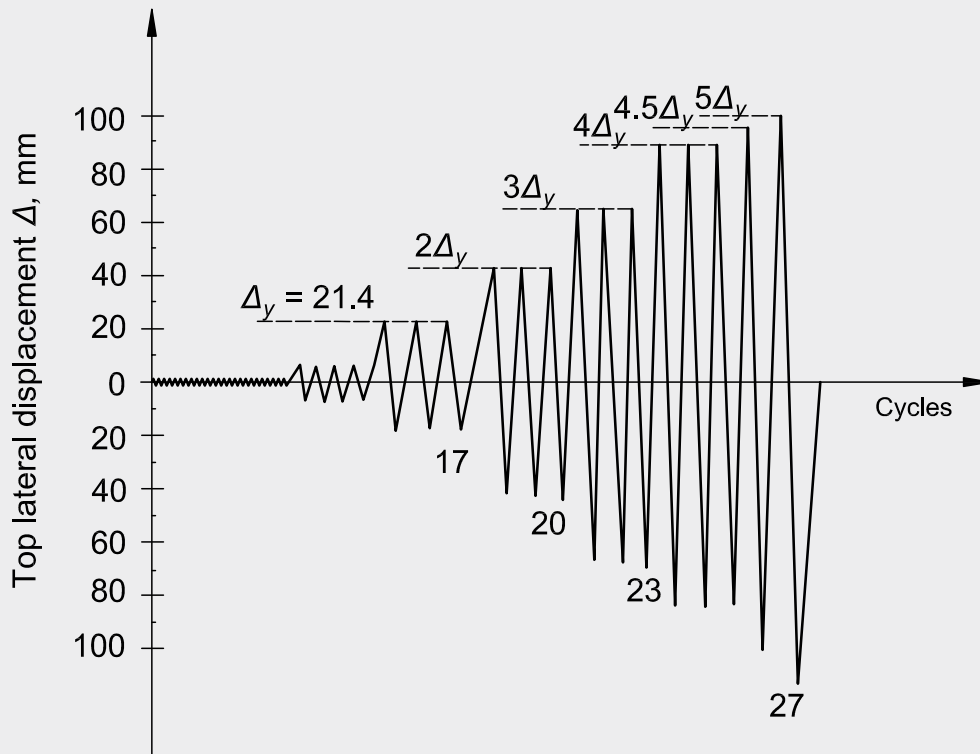

Figure 9. Loading history. Note: Δ_y = top lateral displacement at first yield. 1 mm = 0.0394.

20.94 ft/sec²); and harmonic type earthquake (a_{0max} of 1.943 m/sec² [6.375 ft/sec²]). The shake table tests increased in intensity from V to X on the MM scale.



Figure 10. Precast concrete shear wall after failure.

The most significant results and conclusions are as follows:

- The static tests intermingled among the dynamic tests did not produce damage in the experimental model. **Figure 13** presents lateral displacements recorded for each floor, where A corresponds to the elastic stage, B was conducted after cracking, C corresponds to the elastic-plastic stage when the columns and shear panels have open cracks, and D was performed in the presence of plastic zones in the structure. By comparing the static deformations recorded at different stages of structural behavior (A, B, C, and D), a lateral stiffness degradation of 12.50% was observed in the final failure stage (Fig. 13).
- Cracks appeared, propagated, and widened only in the vertical elements (columns and shear panels) at the bottom of the first floor. Horizontal cracks appeared at intensity level VIII on the MM scale, reaching their maximum width of 1 mm (0.04 in.) in the last test, which corresponds to the seismic intensity degree of X on the MM scale. The lateral interstory drifts recorded during the tests are: 1/600 to 1/400 at the seismic intensity of VIII, 1/275 to 1/125 at IX, and 1/122 to 1/80 at X on the MM scale. It must be emphasized that the prototype designed for the seismic intensity of VIII on the MM scale satisfies the requirements of the Romanian *Seismic Design Code P 100-1/2006*⁵ in

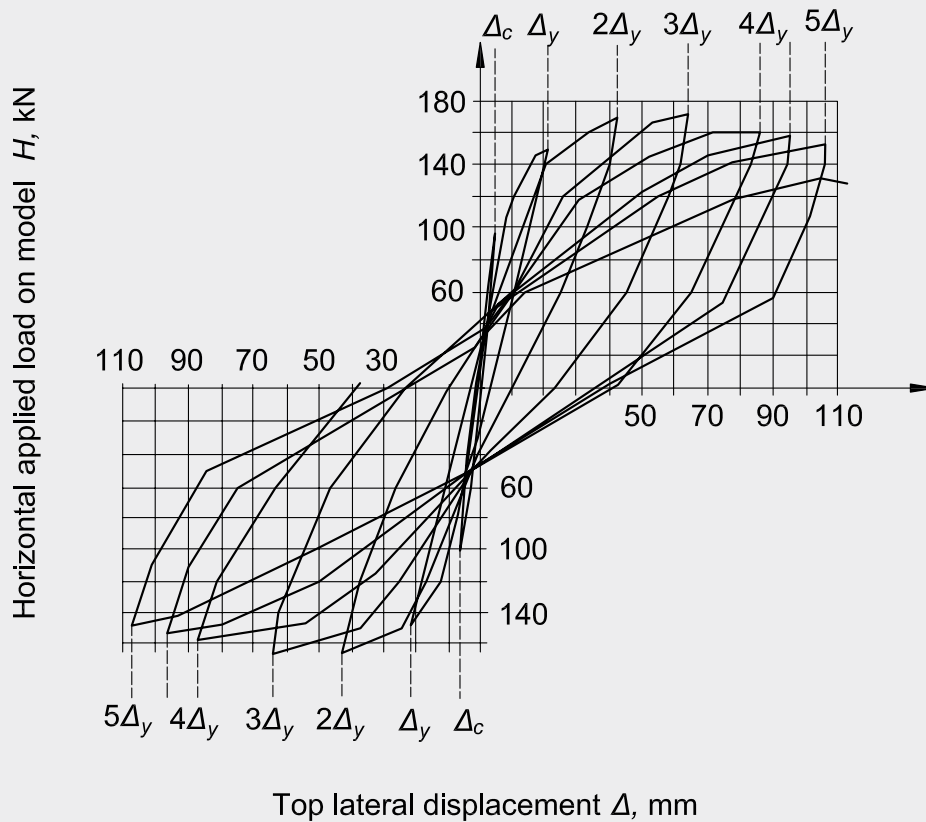

Figure 11. Lateral load–top lateral displacement envelope curves. Note: H = horizontal applied load on model; Δ_c = cracking displacement; Δ_y = top lateral displacement at first yield. 1 mm = 0.0394 in.; 1 kN = 0.225 kip.

the ultimate limit state, where the allowable interstory drift is 2.5%, even for earthquakes of X on the MM scale, where the measured maximum interstory drifts are of 0.82% to 1.25%.

- The tests to determine the dynamic characteristics within five different stages of structural behavior, from the elastic to the plastic stage, showed that the natural frequency of the model diminished from 6.50 Hz to 5.00 Hz in the transverse direction and from 6.00 Hz to 5.03 Hz in the longitudinal direction. At the same time, the critical damping ratio increased from 1.38 to 3.10 in the transverse direction and from 1.00 to 3.02 in the longitudinal direction. Despite reductions of frequency by 23% transversally, 16% longitudinally, and 29% in torsion, the stiffness degradation after a series of high-intensity seismic actions was only 12.50%, which shows that the structure can be consolidated and its structural integrity can be restored.

In-place dynamic test on a real structure

Working with experts from INCERC-Bucharest, the authors coordinated an in-place investigation to determine the dynamic characteristics of a real structure that has three

spans of 3.60 m (11.8 ft), ten bays of 3.90 m (12.8 ft), and five stories of 3.00 m (9.84 ft) high.

Comparisons have been made between the dynamic characteristics of a precast concrete structure comprising only structural columns, panels, and walls (the first stage) and



Figure 12. Five-story precast concrete structure (model scale 1:4) during shake table tests.

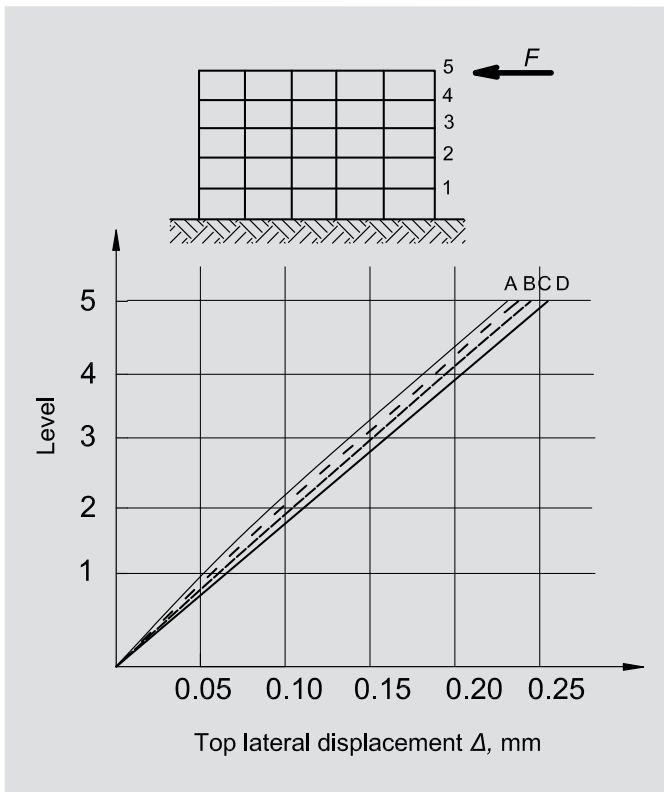

Figure 13. Lateral displacements–static horizontal load diagrams. Note: Test A corresponds to the elastic stage, test B was conducted after the cracking, test C corresponds to the elastic-plastic stage, and test D was performed in the presence of plastic zones in the structure. F = static horizontal load = 6 kN. 1 mm = 0.0394 in.; 1 kN = 0.225 kip.

those of the second testing stage, when the structure also had nonstructural walls (partitions) mounted.

A large volume of experimental data related to the structural response under five different types of dynamic excitations was recorded, and detailed conclusions are presented in the author's PhD thesis.²

The main observations are as follows:

- The nonstructural walls significantly increased the stiffness and damping capacity of the building. Thus, the natural period of vibration decreased from 0.63 sec to 0.32 sec in the longitudinal direction and from 0.40 sec to 0.32 sec in the transverse direction.
- The damping capacity of the building increased due to the contribution of nonstructural elements, and, consequently, the critical damping ratio increased from 0.01 to 0.05 in the horizontal longitudinal direction.
- The general torsion of the structure is beneficially influenced when nonstructural elements are introduced; the structure becomes stiffer, and the natural period of vibration decreases significantly from 0.44 sec to 0.25 sec.

The natural periods of vibration in place determined on this new type of dual precast concrete structure are simi-



Figure 14. Residential condominiums

lar to the values determined in Bucharest on reinforced concrete frame structures with infill masonry panels; those structures exhibited good behavior during the March 4, 1977, Vrancea earthquake (M_w of 7.5).

Conclusion

In an attempt to solve the difficult problem of the construction of residential buildings in Romania, the design team proposed a new all-precaster concrete system of a dual flat-slab type.

To assess the quality and performance of this system, an extensive program of theoretical analyses, structural tests, and applied studies to improve the construction technology were conducted. These studies maximized the effect on construction productivity and minimized the total cost.

A full-scale test on an assemblage of precast concrete columns and precast concrete flat slabs confirms the generally good behavior of the structure under gravity loads and underlines the large load-bearing capacity of the structure. The ratio between the experimental and the theoretical values of the ultimate load is 2.10.

The large subassemblage of two precast concrete, five-story structural walls; four precast concrete columns; and five precast concrete flat slabs was tested up to failure. The loading consisted of constant vertical forces and horizontal forces applied in alternate cycles following the principle of imposed displacements. The test on this model (scale 1:2.5) confirmed its structural performance with respect to the load-bearing capacity, stiffness, ductility, and cracking. The experimental values regarding the ultimate capacity and lateral displacements are in good agreement with the theoretical ones. The hysteretic loops ($H-\Delta$) are stable, and the prototype demonstrated a large energy absorption capacity.

The types of connections proved suitable, resulting in a behavior for the precast concrete subassemblage that was similar to that of the monolithic solution.

The dynamic tests carried out on the 140 kN (315 kip) shake table at INCERC-Jassy, where a five-story precast concrete structure (scale 1:4) was tested, showed that the lateral stiffness degradation of the structure was only 12.5% in the final failure stage. The tests took 900 seconds and had 70 acceleration peaks of more than 1 m/sec^2 (3 ft/sec^2). The interstory drifts recorded during the tests satisfy the requirements of the Romanian Seismic Design Code P 100-1/2006.⁵

In-place tests on a real structure erected in the city of Deva indicated that the natural periods of vibration of this new type of precast concrete structure are similar to the values determined in Bucharest on reinforced concrete frame structures with infill masonry panels. These structures ex-

hibited good behavior during the 1977 Vrancea earthquake (M_w of 7.5).

Due to its functional and technical advantages, high productivity, and low costs, the constructive system has been used in more than 500 flats in Transylvania, Romania. Three hundred apartments are in five- to nine-story buildings (Fig. 14), and 200 are in residential condominiums that have to five stories.

References

1. Crainic, L. 2003. *Reinforced Concrete Structure*. Cluj-Napoca, Romania: Napoca Star.
2. Tripa, E. 2002. Contributions to the Study, Design and Erection of Buildings with Precast Concrete Mixed Structure. [In Romanian.] PhD thesis. University Politehnica from Timișoara (UPT), Timișoara, Romania.
3. Lungu, D., C. Arion, S. Demetriu, and A. Aldea. 2003. Probabilistic Zonation of Vrancea Seismic Hazard. Eurocode 8, Representation of Design Actions. In *Proceedings of the International Conference: Constructions 2003, July 16–17, 2003*. Cluj-Napoca, Romania: Napoca Star and Argonaut.
4. Ministry of Public Works and Territory Management (MLPAT). 1992. *Seismic Design Code (P100-92)*. [In Romanian.] Bucharest, Romania: MLPAT.
5. Ministry of Transportation, Construction and Tourism (MTCT). 2006. *Seismic Design Code—Part I: Provisions for Buildings (P 100-1/2006)*. [In Romanian.] Bucharest, Romania: MTCT.
6. Federal Emergency Management Agency (FEMA). 2000. *Prestandard and Commentary for the Seismic Rehabilitation of Buildings*. FEMA 356. Washington, DC: FEMA.
7. American Concrete Institute (ACI) Committee 318. 2008. *Building Code Requirements for Structural Concrete (ACI 318-08) and Commentary (ACI 318R-08)*. Farmington Hills, MI: ACI.
8. European Committee of Standardization (CEN). 2004. EN 1992-1-1: 2004. In *Eurocode 2: Design of Concrete Structures—Part 1-1: General Rules and Rules for Buildings*. Brussels, Belgium: CEN.
9. Romanian Standards Association (ASRO). 2004. SR EN 1992-1-1: 2004. In *Eurocode 2: Design of Concrete Structures—Part 1-1: General Rules and Rules for Buildings*. [In Romanian.] Bucharest, Romania: ASRO.

10. Romanian Standards Institute (IRS). 1990. *Reinforced and Prestressed Concrete Floors. General Design Specifications*. In *Civil and Industrial Buildings*. STAS 10107/1-90. [In Romanian.] Bucharest, Romania: IRS.
11. IRS. 1990. *Design and Detailing of Concrete, Reinforced and Prestressed Concrete Structural Members*. In *Civil and Industrial Buildings*. STAS 10107/0-90. [In Romanian.] Bucharest, Romania: IRS.
12. Maniu, H., A. M. Ioani, and E. Tripa. 1992. Structural Investigation on a Seismic Performance of Precast Mixed Shear Walls. In *Proceedings of the Tenth World Conference on Earthquake Engineering, Madrid, July 19-24, 1992*. Rotterdam, Netherlands: Balkema.

- Δ^v = vertical displacement (deflection)
- Δ_a^v = allowable vertical displacement (deflection) specified by design code
- Δ_{max}^v = experimental maximum vertical deflection
- Δ_c = cracking displacement
- Δ_u = ultimate top lateral displacement
- Δ_u/Δ_y = displacement ductility factor
- Δ_y = top lateral displacement at first yield

Notation

- a_{0max} = maximum values of accelerations (acceleration peaks) applied during dynamic tests
- F = static horizontal load applied during shake table tests
- g = acceleration due to gravity = 9.81 m/sec² (32.2 ft/sec²)
- H = horizontal applied load on model
- L = length (span) of precast concrete slab panels
- M_w = magnitude of earthquake on the moment magnitude scale (MMS)
- N_1 = vertically applied forces on model
- N_g = gravity load (dead load) on model
- P = gravity load applied on the full-scale assemblage
- P_{cr}^d = design (calculated) cracking load for the full-scale assemblage
- P_u^d = design (calculated) ultimate gravity load for the full-scale assemblage
- P_u^{exp} = experimental (measured) ultimate gravity load applied on the full-scale assemblage
- Δ = top lateral displacement
- Δ_{max}^d = design (calculated) maximum (ultimate) top lateral displacement
- Δ_{max}^{exp} = experimental maximum (ultimate) top lateral displacement

About the authors



Adrian M. Ioani, PhD, FACI, FAICPS-Romania, is a professor of structural mechanics at the Technical University of Cluj-Napoca in Romania and former director of INCERC-Cluj (National Building Research Institute).



Eusebiu Tripa, PhD, P.E., FAICPS-Romania, is a senior structural engineer at Tripexpert Design Office in Deva, Romania.

Abstract

This paper discusses a new all-precast concrete system used in Romania to construct a residential building. Designed for constructability, a new all-precast concrete system comprising columns, flat slabs, and structural walls was proposed by the design team. To validate the structural quality and performance of this type of structure, an extensive program of theoretical

analyses and structural tests (including shake table tests) was conducted. The tests demonstrated good behavior of the precast concrete dual system (frame-wall) adapted for a classic flat-slab structure. The connections resulted in a similar behavior of the precast concrete system to that of the monolithic solution. Due to its functional and technical advantages, high productivity, and low cost, this system has been used in more than 500 flats in Transylvania, Romania.

Keywords

Connection, dual system, flat-slab panel, loading, seismic.

Review policy

This paper was reviewed in accordance with the Precast/Prestressed Concrete Institute's peer-review process.

Reader comments

Please address any reader comments to journal@pci.org or Precast/Prestressed Concrete Institute, c/o PCI Journal, 200 W. Adams St., Suite 2100, Chicago, IL 60606. ¶